

Mounting instructions

IBK in-concrete duct system



IBK in-concrete duct system

Mounting instructions

Table of content

1	About these instructions	5
1.1	Target group	5
1.2	Relevance of these instructions	5
1.3	Types of warning information	5
1.4	Basic standards and regulations	6
1.5	Applicable documents	6
2	Intended use	6
3	Safety	6
3.1	General safety information	6
3.2	Personal protective equipment	7
4	Necessary tools	7
5	System overview	8
5.1	System description	8
5.1.1	In-concrete socket	9
5.1.2	Base plate	11
5.1.3	Electrical installation duct with connection shackle	11
5.1.4	Connection shackle	12
5.1.5	Duct support	12
5.1.6	Height-adjustment unit with duct support	13
5.1.7	Vertical bend	14
6	Planning an installation	14
7	Mounting the in-concrete duct system	14
7.1	In-concrete socket	16
7.2	Routing the electrical installation duct	19
7.2.1	Extending the electrical installation duct	19
7.2.2	Installing the electrical installation duct in the in-concrete socket	20
7.3	Mount the vertical bend	25
7.4	Final work before screed laying	26
7.5	Final work after screed laying	27
8	Creating the earthing connection	27
9	Applying the floor covering	27
10	Mounting the cassette/service outlet	28
11	Performing the electrical installation	28
12	Disposing of the in-concrete duct system	29
13	Calculating the length/height ratios	29
13.1	Calculating the length of the electrical installation duct	29

13.2 Height ratios in the in-concrete socket – dimensions.....	31
14 Technical data.....	32
14.1 In-concrete socket.....	32
14.2 Underfloor duct.....	32
14.3 Vertical bend.....	32
14.4 Connection shackle.....	32
14.5 Support element.....	33
14.6 Height adjustment unit.....	33

1 About these instructions

1.1 Target group



These instructions are intended for the following target groups:

- Electrically trained specialists charged with mounting in-concrete duct systems
- Electrical planners and engineers charged with the planning of under-floor systems

Electrical work may only be carried out by specialist personnel with electrical training.

1.2 Relevance of these instructions

These instructions are based on the standards valid at the time of compilation (March 2024).

Please read the instructions carefully before starting mounting. We will not accept any warranty claims for damage and liability caused through non-observance of these instructions.

All the documents supplied with the product must be stored in an easily accessible location, so as to be available when information is required.

To find out more about planning and mounting the product, we recommend a comprehensive training course.

1.3 Types of warning information

 **DANGER**

Type of risk!

Shows a risky situation. If the warning information is not observed, then fatal injuries may occur.

 **WARNING**

Type of risk!

Shows a risky situation. If the warning information is not observed, then serious or fatal injuries may occur.

 **CAUTION**

Type of risk!

Shows a risky situation. If the warning information is not observed, then medium or minor injuries may occur.

ATTENTION

Type of risk!

Shows a risky situation. If the warning information is not observed, then damage to the product or the surroundings may occur.

Note!

Indicates important information or assistance.

1.4 Basic standards and regulations

- EN 50085 Part 2-2: Cable trunking systems and cable ducting systems for electrical installations: Particular requirements for cable trunking systems and cable ducting systems intended for mounting underfloor, flush-floor or on-floor
- DIN VDE 0100: Low-voltage electrical installations
- EN 50310: Telecommunications bonding networks for buildings and other structures
- EN 50173: Information technology – Generic cabling systems
- EN 50174-2: Information technology – Cabling installation – Part 2: Installation planning and practices inside buildings

1.5 Applicable documents

The declarations of conformity are linked to the products at www.obo-bettermann.com.

2 Intended use

The in-concrete duct system is suitable for use in concrete floor plates and concrete ceilings – in structurally lined ceilings or in ceilings made of filament plates.

The in-concrete duct system is used as a:

- Duct system for electrical installations
- Seat for device installation units
- Access to the installations possible at any time

The ducts are located in the neutral zone between the upper and lower reinforcement and can also be used for simultaneous concrete core activation – cooling and heating via the floor or the ceiling.

Note! *The planning of the in-concrete duct system must be agreed with architects and structural engineers.*

3 Safety

3.1 General safety information

Observe the following general safety information:

- All the mounting work may only be carried out by electricians or

mounting engineers for underfloor systems, who have been trained in the installation of in-concrete duct systems.

- The in-concrete duct system must be included in the protection measures or the equipotential bonding.
- If the in-concrete duct system passes through fire sections and/or escape and rescue routes, then the (M)LAR cable systems guideline and the (M)SysBör system floors directive must be observed.
- Always wear protective gloves for all mounting work.

3.2 Personal protective equipment

List of personal protective equipment to be used:



Use hand protection



Wear safety shoes



Wear protective goggles

4 Necessary tools

List of tools to be used:

- Battery-powered screwdriver
- Ring spanner (WAF 11 and 13)
- Wire retaining loop, tape
- Slotted screwdriver
- OBO anchor
- OBO flattener
- Laser measurement device or chalk line
- Spirit level
- Angle grinder
- Philips screwdriver
- Adhesive tape (width: 50 mm)

5 System overview

5.1 System description





Abb. 1: System description, IBK

No.	Product name	Figure	Function
1	In-concrete socket		In-concrete socket for duct height 38 and 48 mm, prepared for duct widths 250 and 350 mm. With four adjustable seats for height-adjustment units. The integrated lined body can be adjusted to a maximum of 65 mm for compensating screed work.
2	Connection shackle		Connection shackle (2-part) for conductive mounting of electrical installation ducts. The connection shackle snaps in to the duct side walls.
3	Electrical installation duct		Electrical installation duct (2-part) for routing of cables in the in-concrete duct system according to EN 50085-2-2. Removable and continuously lockable duct cover. With separating retainer in the duct base.
4	Duct support		Electrical installation ducts with a length of more than 1 m must be additionally supported. One duct support is to be mounted per running metre
5	Height adjustment unit		Height adjustment kit for IBK system components. To adjust the height of the sockets, connectors and supports.
6	Vertical bend		Vertical bend (2-part) for vertical changes of direction of electrical installation ducts (wall connections, infeeds).

Tab. 1: System description, IBK

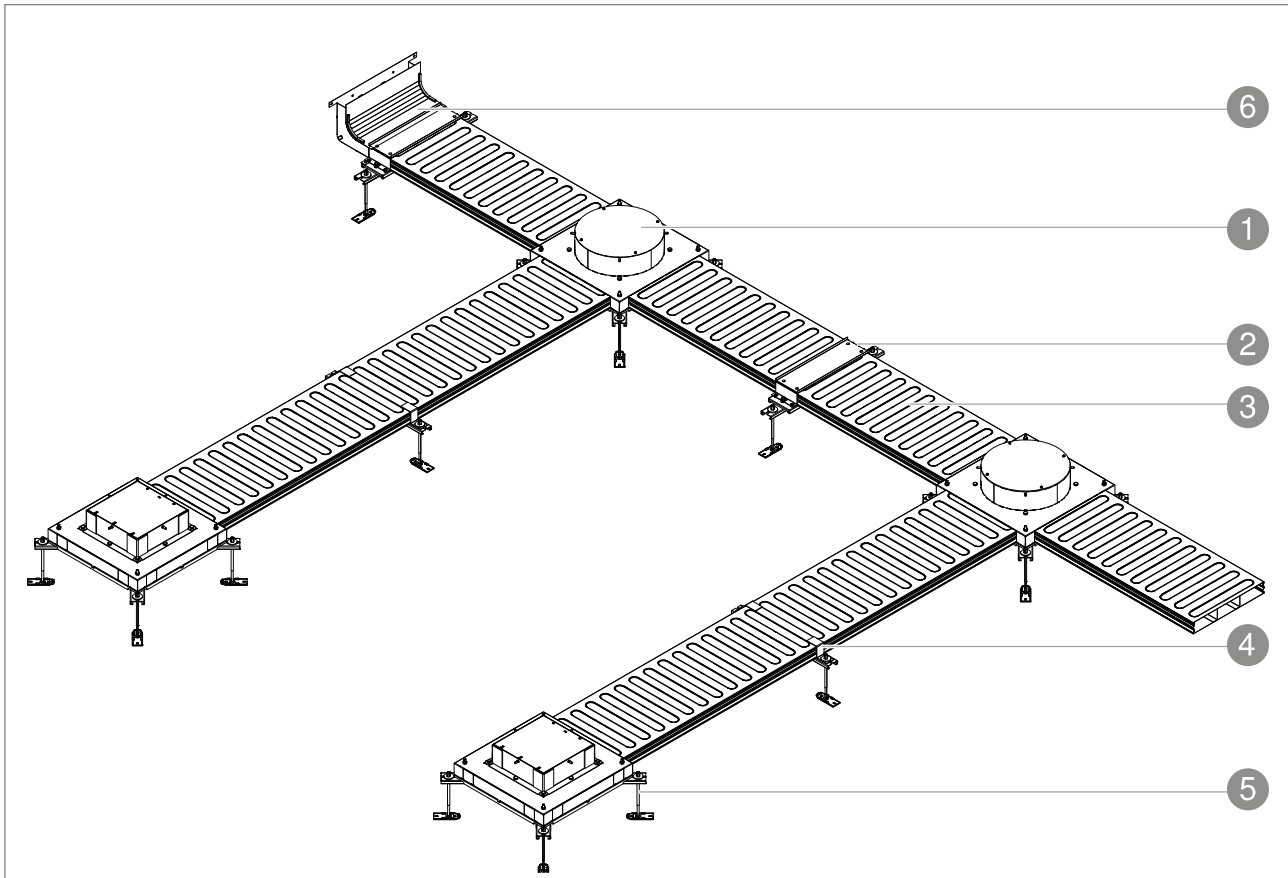
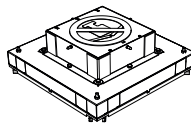
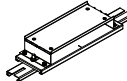
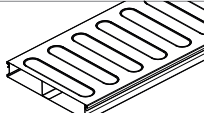
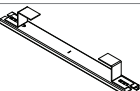
The IBK system has been further developed for special installation in concrete and simplified for mounting. With the IBK system, large floor areas can be connected with electrical installation systems, if there is no or only a small screed structure. Duct lengths and box bodies form a tight grid cable routing lines in the concrete surface. The IBK boxes are intended for the later, direct installation of devices.

The new IBK system is suitable for duct heights of 38 mm or 48 mm. The system elements, which are made from galvanised sheet steel, are suitable for high mechanical loads during the raw construction phase.

Thanks to the continuous height adjustment of the ducts and sockets, it is possible to adapt the system to all kinds of project requirements. The base plate of the service outlet, the connection elements and the supports all have the same height.

The IBK system is simple to mount, is robust and can be integrated perfectly into buildings. It is matched to the latest developments in the construction industry – to concrete activation technology and to current fire protection guidelines.

5.1.1 In-concrete socket

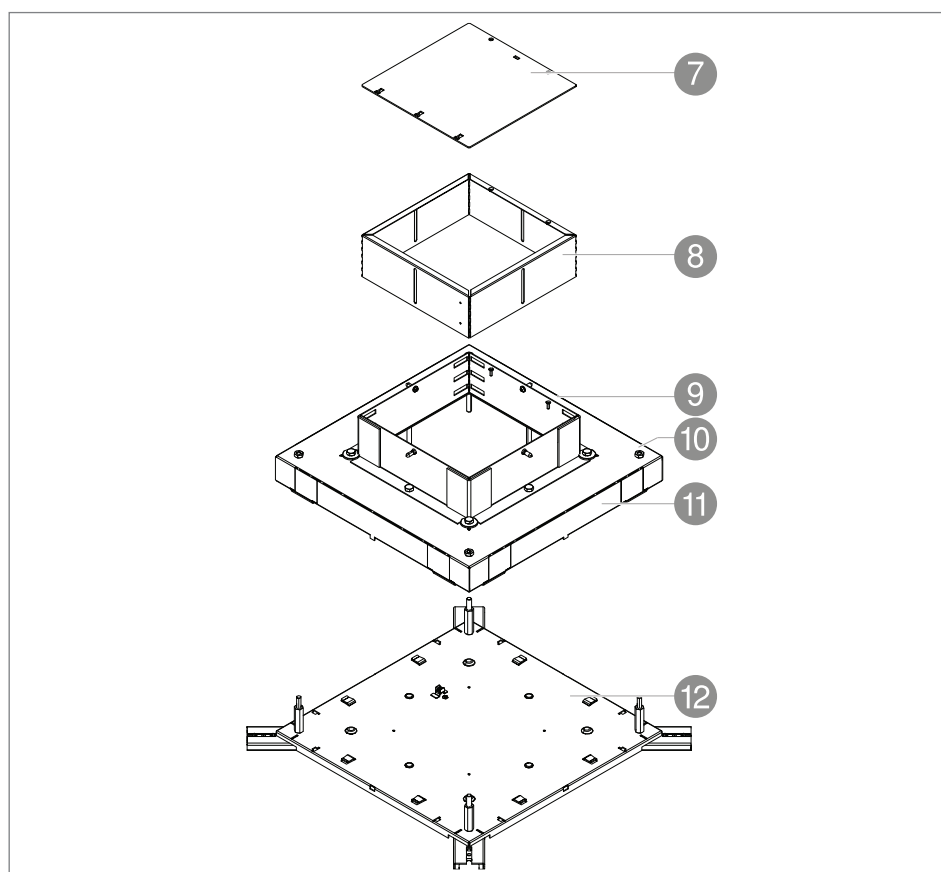

Fig. 2: Product description, in-concrete socket

- ⑦ Mounting protection cover
- ⑧ Inner lined body

- ⑨ Socket body for device installation (socket body)
- ⑩ Socket body fastening nut
- ⑪ Breakable side section
- ⑫ Base plate

Mounting protection cover

The IBK system remains closed with the mounting protection cover until device installation, meaning it is fully protected against dirt without any need for masking. The mounting protection cover prevents workplace accidents during the construction phase and is so robust that it cannot be damaged by concrete work and the mechanical processing of concrete areas. The mounting protection cover is suspended in the inner lined body and fixed with screws.

Inner lined body

If a compensation layer is additionally applied to the concrete ceiling, then the inner, pull-out lined body serves as lining. The slots of the inner lined body correspond to a screed grain size of 7 mm and do not need to be closed during screed laying.

Socket top for device installation (socket body)

The socket body can accept the various different service outlets without any further reworking. The base of the socket body is equipped with pre-punched side sections, which, depending on the electrical installation duct used, can be broken out in two widths without the need for tools. The slots on the sides of the cover later accept the fastening units of the service outlets. During the concrete work, the slots are closed by the inner lined body.

Base plate

On each side, the base plate is equipped with side duct guides and contacting retaining straps to accept the electrical installation ducts. The base plate has an earthing connection. The swivellable fastening shackles for retention of the height-adjustment units are fixed with the long nuts.

The in-concrete socket is available in a round and rectangular shape. Both variants are available in two heights. The heights correspond to the heights of the electrical installation ducts. In the mounted state, the in-concrete socket is supplied with fastening shackles swivelled inwards. It is positioned in the neutral layer between the upper and lower reinforcement.

Note! *These system instructions only show the rectangular in-concrete socket for all mounting steps. All the work carried out on the round in-concrete socket is identical.*

5.1.2 Base plate

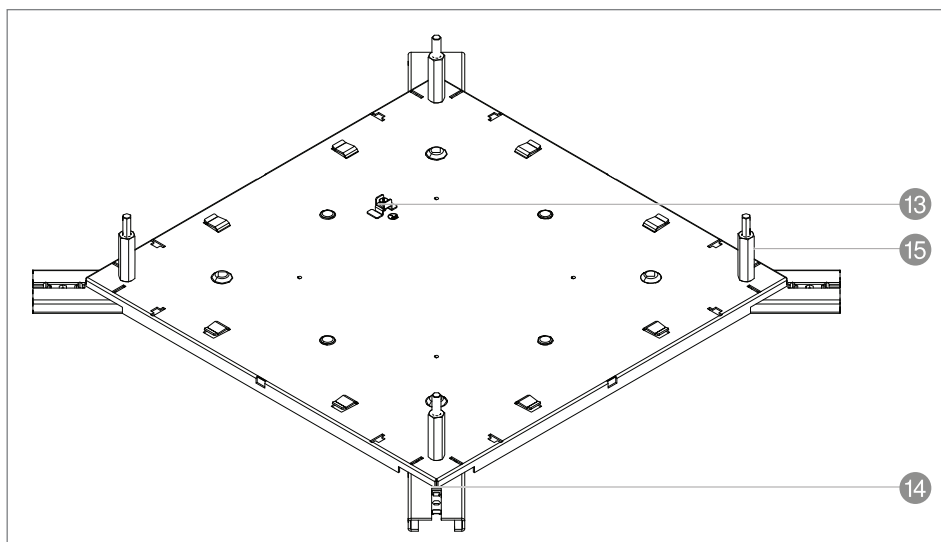

Fig. 3: Product description, base plate

- ⑬ Earthing connection
- ⑭ Swivellable fastening shackles
- ⑮ Long nuts

5.1.3 Electrical installation duct with connection shackle

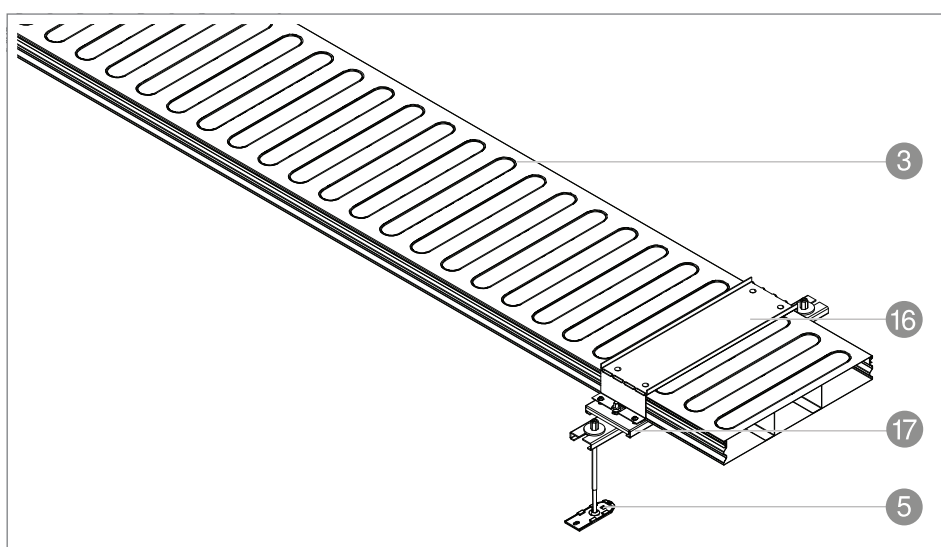

Fig. 4: Product description, electrical installation duct with connection shackle

- ③ Electrical installation duct
- ⑯ Connection shackle cover

17 Connection shackle base

5 Height-adjustment unit

The electrical installation ducts are 2 m long. They have either two or three compartments and are 38/48 mm high. If necessary, they can be shortened or extended with connection shackles.

5.1.4 Connection shackle

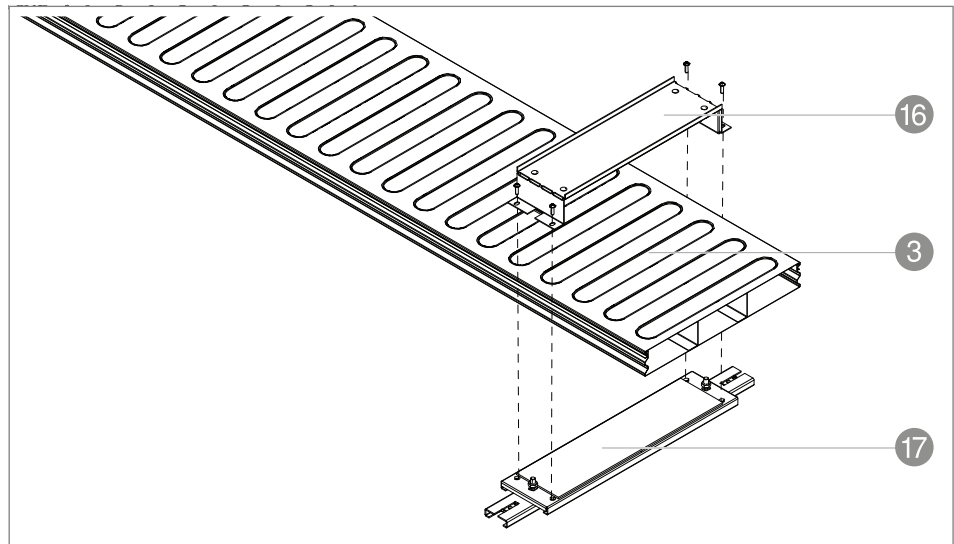

Fig. 5: Product description, duct support

16 Connection shackle cover

3 Electrical installation duct

17 Connection shackle base

The connection shackles consist of a cover and a base and can be taken apart for mounting. As with the in-concrete socket, the slots to accept the height-adjustment units are open on one side. This allows mounting of the height-adjustment units appropriate to the situation.

5.1.5 Duct support

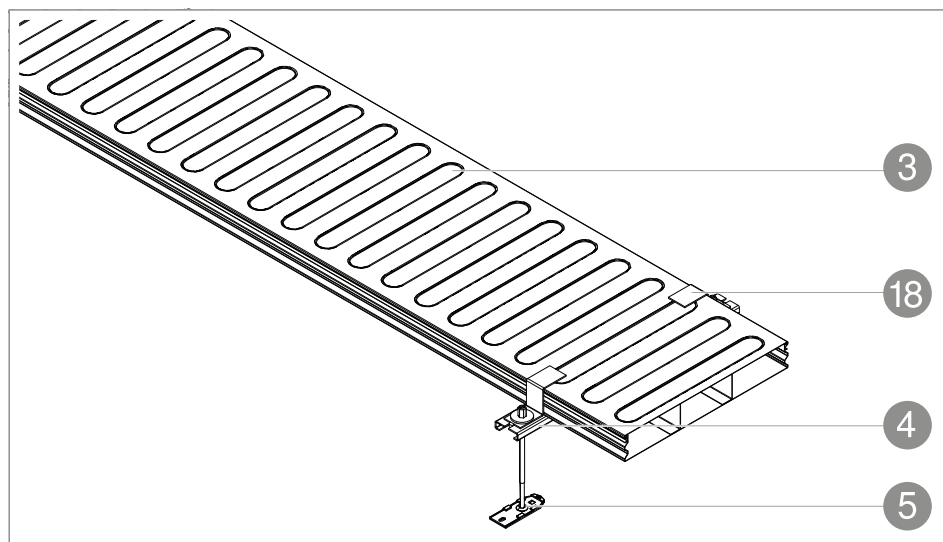

Fig. 6: Product description, duct support

- ③ Electrical installation duct
- ④ Duct support
- ⑤ Height-adjustment unit
- ⑱ Z profile

A duct support comprises a support and two height-adjustment units. The support is equipped with two Z profiles, which must be fastened during the mounting of the entire ducts.

5.1.6 Height-adjustment unit with duct support

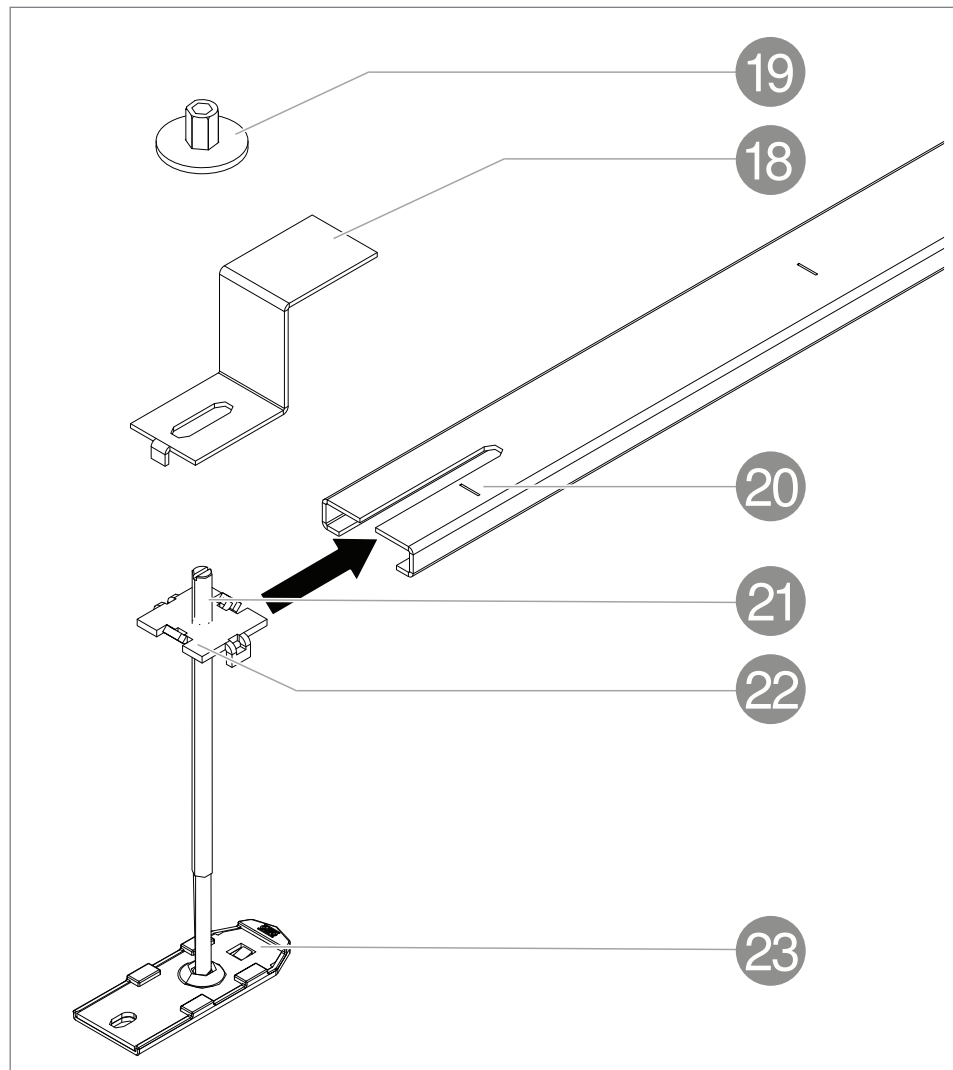

Fig. 7: Product description, height-adjustment unit with duct support

- 18 Z profile
- 19 Flange nut
- 20 Cross traverse (swivellable)
- 21 Height-adjustment screw (slotted screw)
- 22 Locking for height-adjustment screw (if pushed into fastening shackles)
- 23 Height-adjustment unit base

All the elements of the IBK system are fastened to the blinding layer using the height-adjustment units and are adjusted to a standardised height. The fastened height-adjustment units prevent floating of the in-concrete duct system during concreting work.

5.1.7 Vertical bend

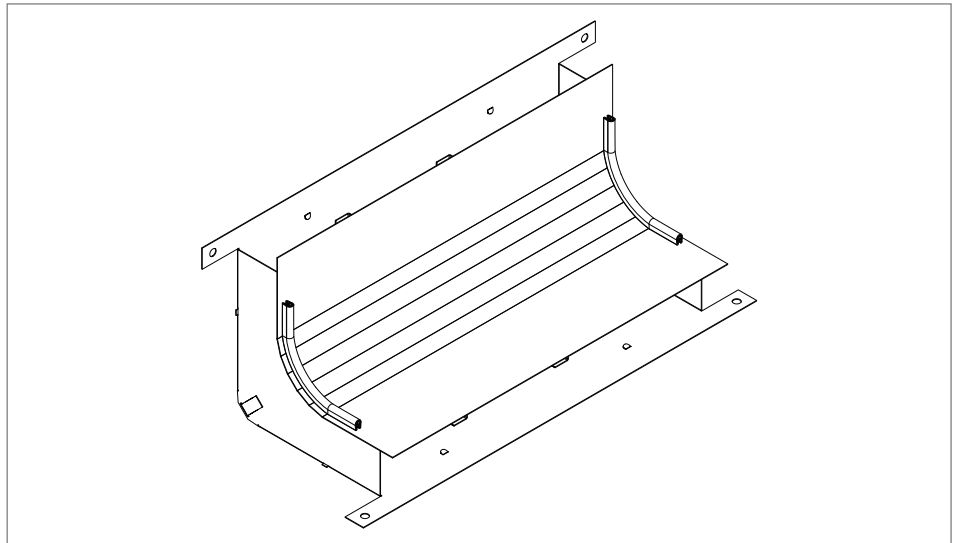

Fig. 8: Product description, vertical bend

Only use the vertical bend in a closed state. Vertical bends are available for the 38 or 48 mm duct heights and for the 250 and 350 mm duct widths. For the exact type specifications, see “Tab. 4: Technical data – vertical bends” on page 33.

6 Planning an installation

When planning and building an IBK system, the following factors must be included in the planning:

- Match with architecture
- Match with statics
- Match with electrical planners
- Match with technical building equipment
- Match with building systems

7 Mounting the in-concrete duct system

Note! *The IBK system is located between the bottom and top reinforcement of the concrete plate. Mounting planning must always be agreed jointly with the other units.*

Sample procedure:

1. Routing the lower reinforcement – concrete layer

2. Routing the IBK system – duct mounting engineers and project-specific work:
 - Routing of the pipe system
 - Concrete core activation
 - HKS units
3. Routing the upper reinforcement – concrete layer
4. Pouring concrete – concrete layer
5. Adjusting the IBK system to the screed height – duct builder
6. Pouring screed – screed layer
7. Preparing the IBK system to accept the device frames – duct mounting engineers

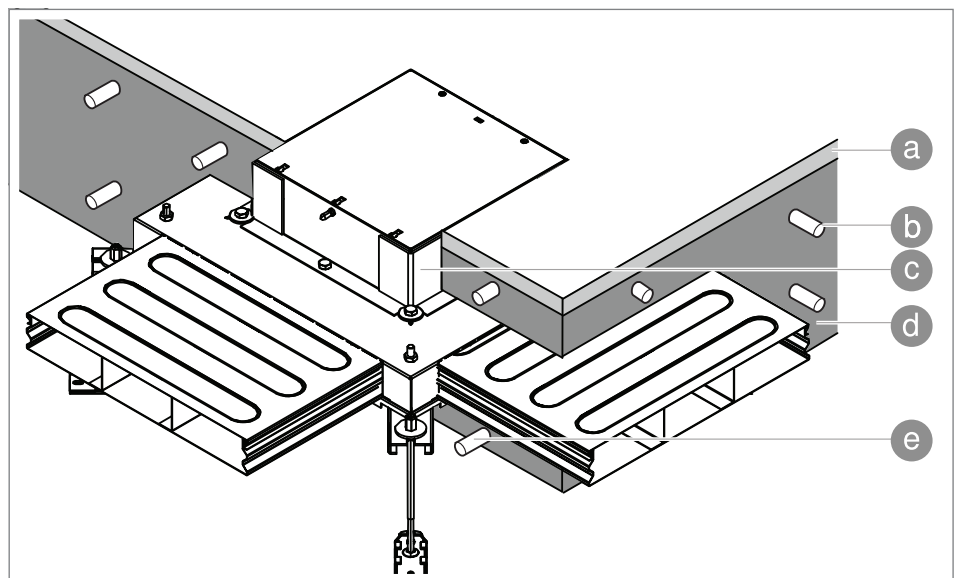

Fig. 9: Floor structure, IBK system

- a Screed compensation layer
- b Upper reinforcement
- c In-concrete socket
- d Concrete
- e Lower reinforcement

Note!

When mounting the system components, their construction, which uses mandrels or contact claws, automatically creates equipotential bonding of the entire IBK system.

Note! *The order of mounting steps for the IBK system may change, depending on the conditions on the construction site! However, the basis is always the mounted and height-adjusted in-concrete socket.*

7.1 In-concrete socket

Note! *For reasons of fire protection, the minimum spacings between the lower edge of the in-concrete duct system and the lining of the concrete ceiling must be taken into account.*

The in-concrete sockets are fastened on the blinding layer according to the sectional planning specified by the architect using the height-adjustment units. Usually, the inner lined body is not extended here. The height is adjusted to the level of the planned concrete layer. After concreting, the top edge of the in-concrete socket is flush with the top edge of the concrete. The in-concrete sockets are located in the “neutral” zone and may be located on the lower reinforcement.

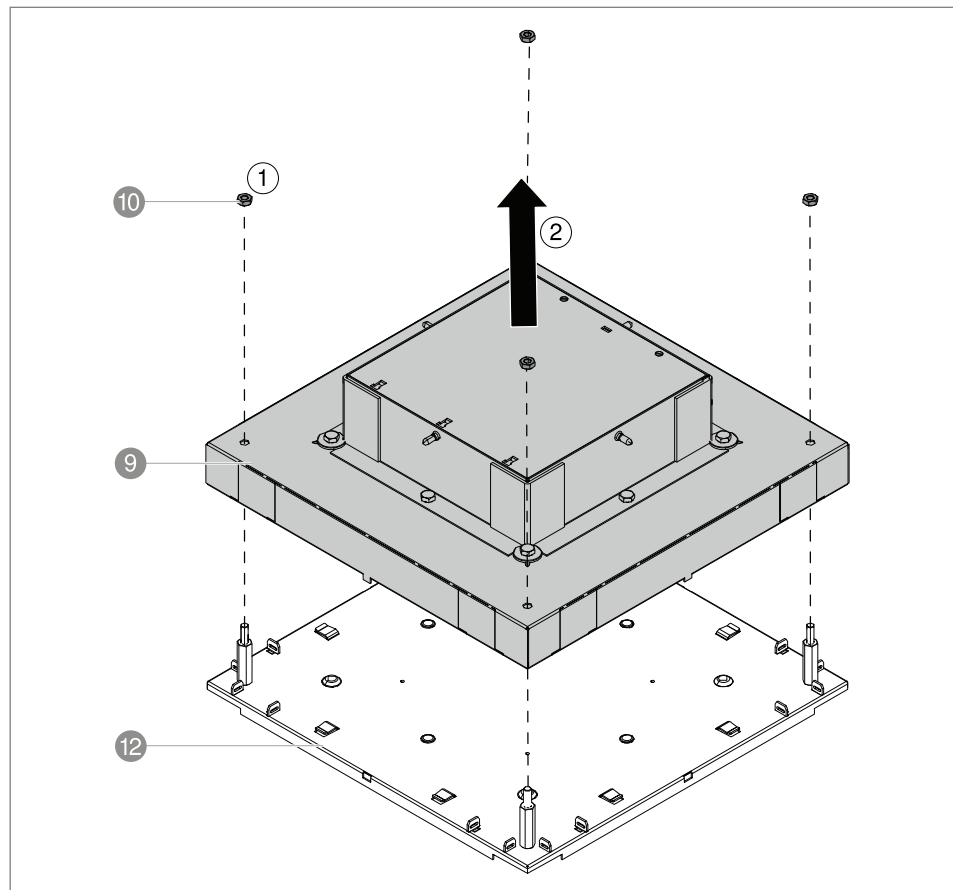

Fig. 10: Releasing the socket body

1. Loosen the fastening nuts ⑩ of the socket body ⑨.
2. Remove the socket body ⑨ from the base plate ⑫.

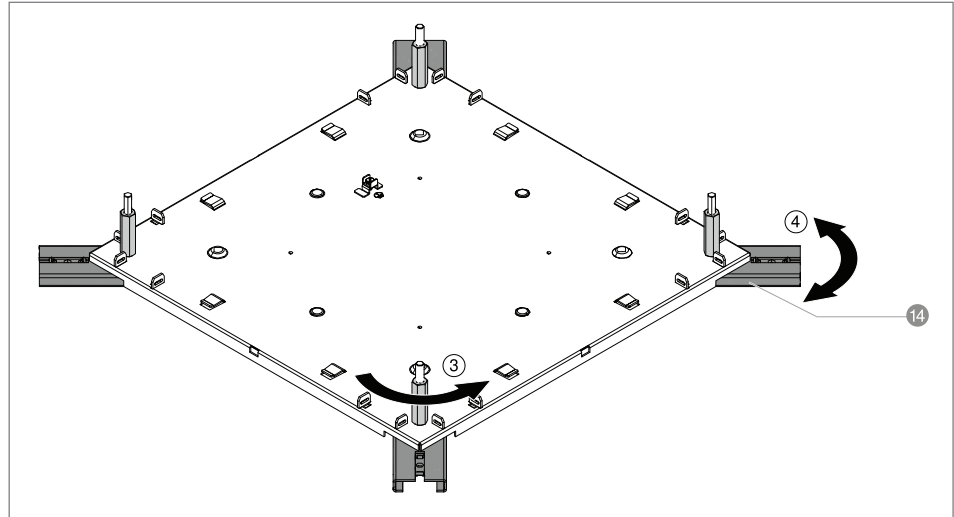

Fig. 11: Mounting the fastening shackles

3. Loosen the height-adjustment sleeves.
4. Swivel the fastening shackles 14 outwards.

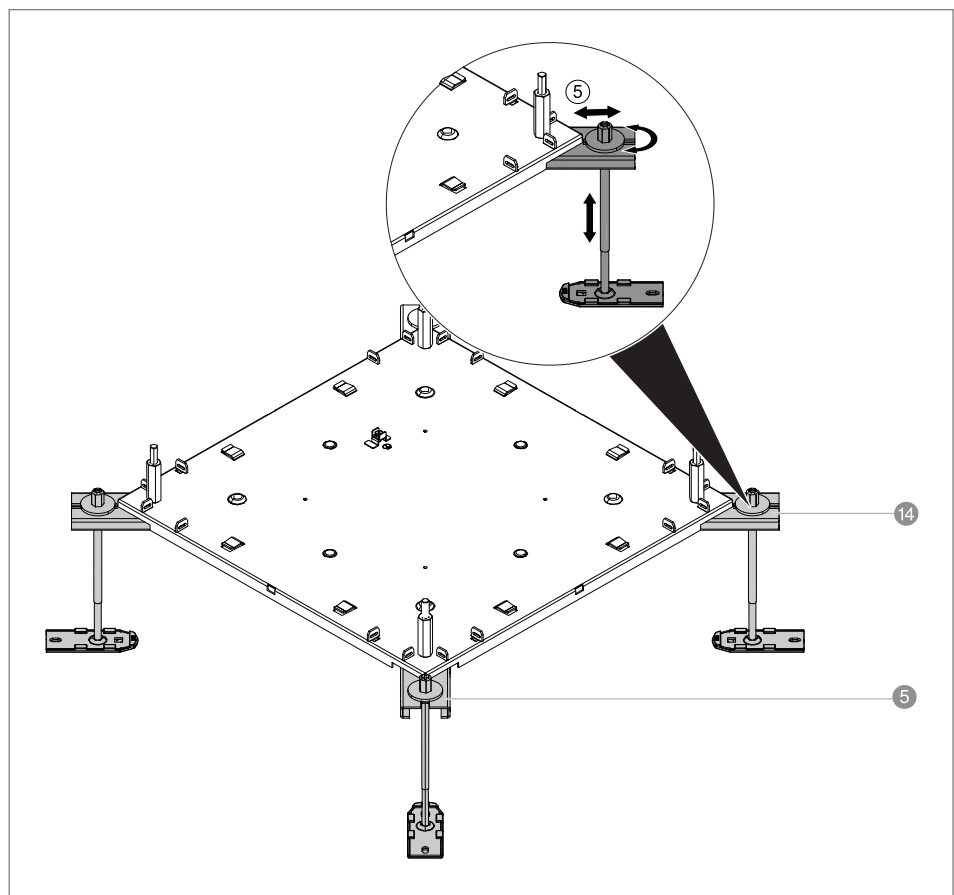

Fig. 12: Mounting height-adjustment units

5. Push the height-adjustment units 5 into the fastening shackles 14.

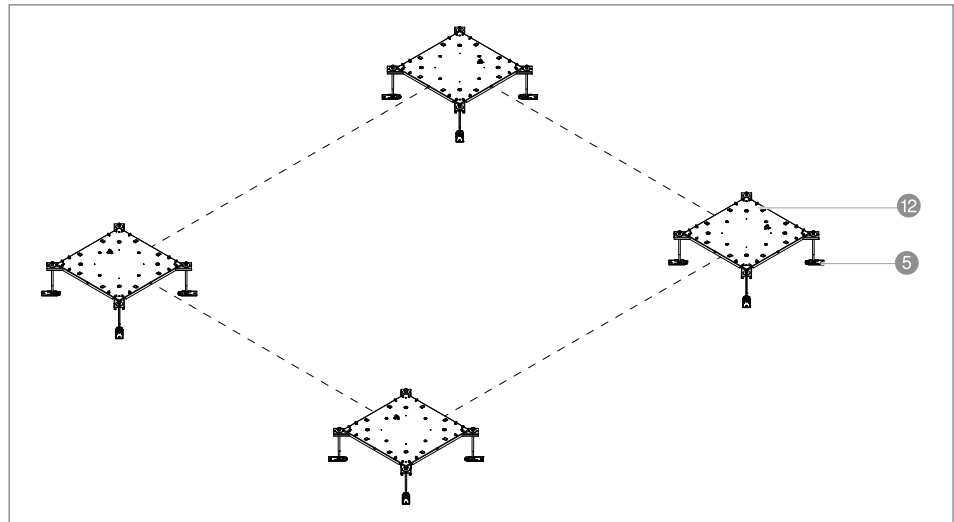

Fig. 13: Aligning the base plate

Note!

For optimum alignment of the base plate, the fastening shackles with the mounted height-adjustment units can still be moved until they are fixed.

6. Position and align the base plates ¹² according to the sectional planning.
7. Position the height adjustment units ⁵ between the strands of the lower reinforcement on the blinding layer and fasten with an OBO anchor with setting iron.

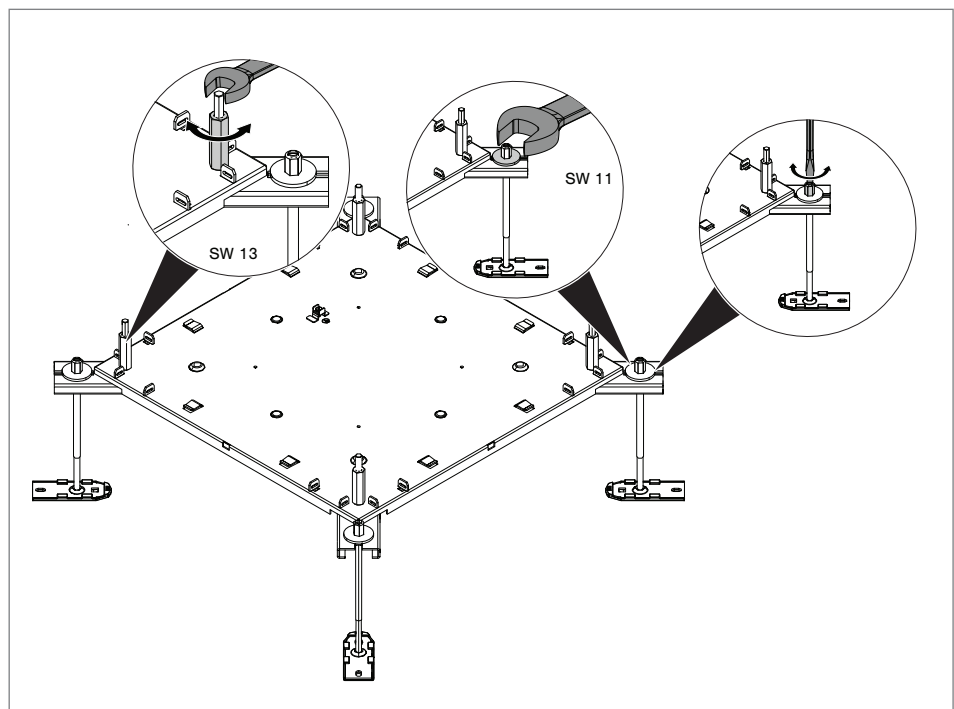

Fig. 14: Fixing the base plate

Note!

The height adjustment is sufficient when the tolerance dimensions of the concrete layer are complied with.

8. Adjust the height of the base plate ¹² using the battery-operated screwdriver via the slotted screws of the height-adjustment units ⁵.
9. Fix the height-adjustment units ⁵ with flange nuts i (e.g. ring spanner WAF 11).
10. Fix the fastening shackles ¹⁴ with long nuts (e.g. ring spanner WAF 13).

7.2 Routing the electrical installation duct

To mount the electrical installation ducts, the upper socket body must have been unscrewed from the base plate. In the upper socket body, the side parts must be broken out to match the size of the inserted electrical installation ducts. Make the electrical installation ducts the right length.

- If necessary, shorten the electrical installation ducts.
- If necessary, extend the electrical installation ducts.

7.2.1 Extending the electrical installation duct

Every two electrical installation ducts are abutted using connection shackles. In the fully mounted state, the cover of the connection shackles is clamped in the locking contour of the electrical installation duct. The connection shackles are adjusted to the height of the base plate using height-adjustment units and fastened on the blinding layer.

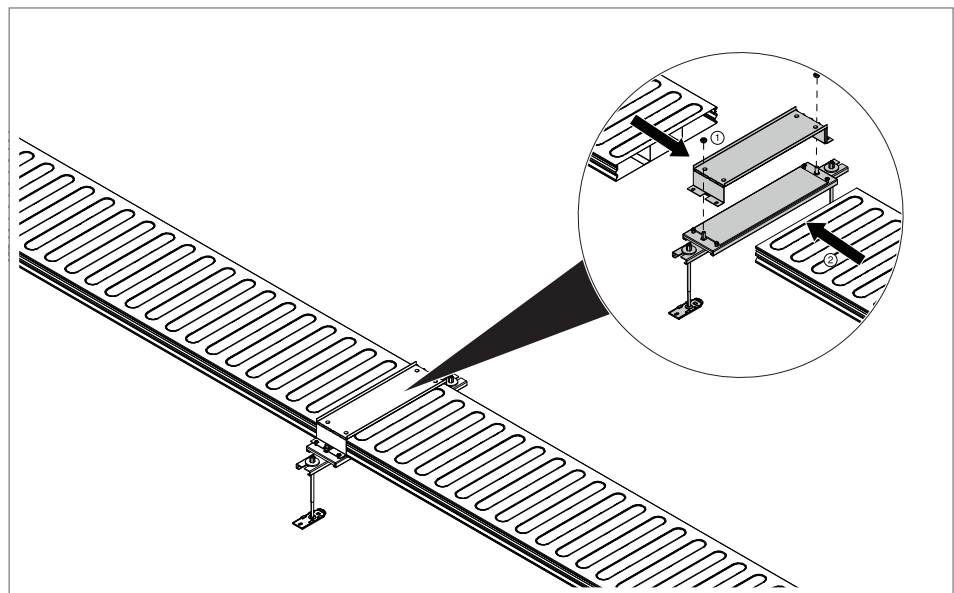

Fig. 15: Extending the electrical installation ducts

Note! *With the two-compartment underfloor ducts, the positioning of the separating retainers must be taken into account.*

Note! *Depending on the conditions on the construction site, the connection shackles in the cover and base can be dismantled or the connection*

of the cover and base is loosened, so that the beading of the electrical installation ducts can be pushed in.

1. Loosen the connection shackles ② ①.
2. To extend them, push the electrical installation ducts ③ into the connection shackles ② ②.
3. Tighten the connection shackles ② whilst clamping the electrical installation duct ③.

7.2.2 Installing the electrical installation duct in the in-concrete socket

Preparing the top socket body

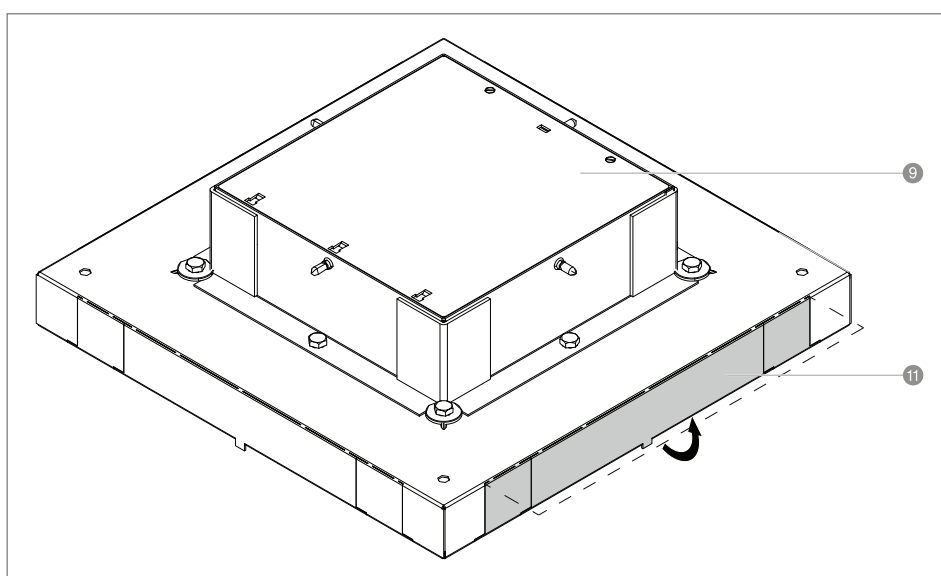

Fig. 16: Breaking out the side sections in the socket body

1. Break out the breakable side sections ⑪ in the socket body ⑨ to the dimension of the widths of the electrical installation ducts used.

7.2.2.1 Pushing in the electrical installation ducts

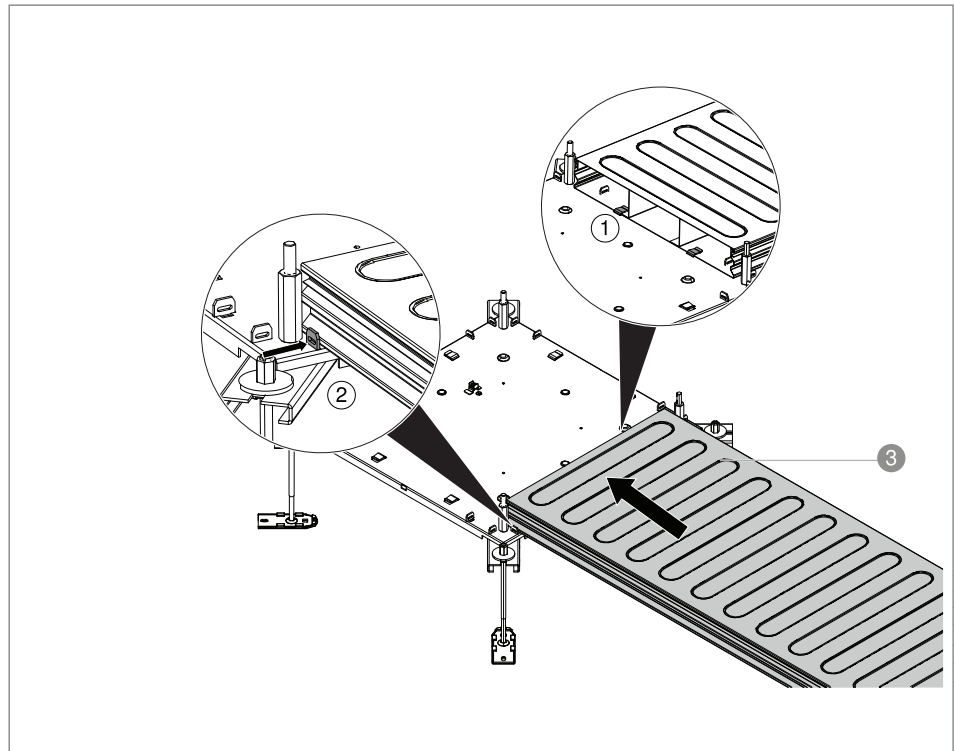

Fig. 17: Pushing in the electrical installation ducts

Note! *When mounting 350 mm electrical installation ducts, the inner duct guides at the side must be pushed downwards.*

1. Push the electrical installation ducts ③ into the contacting retaining straps of the base plate.

Note! *There must be a 10 mm spacing between the side wall of the duct and the beading, so that the socket body can be positioned.*

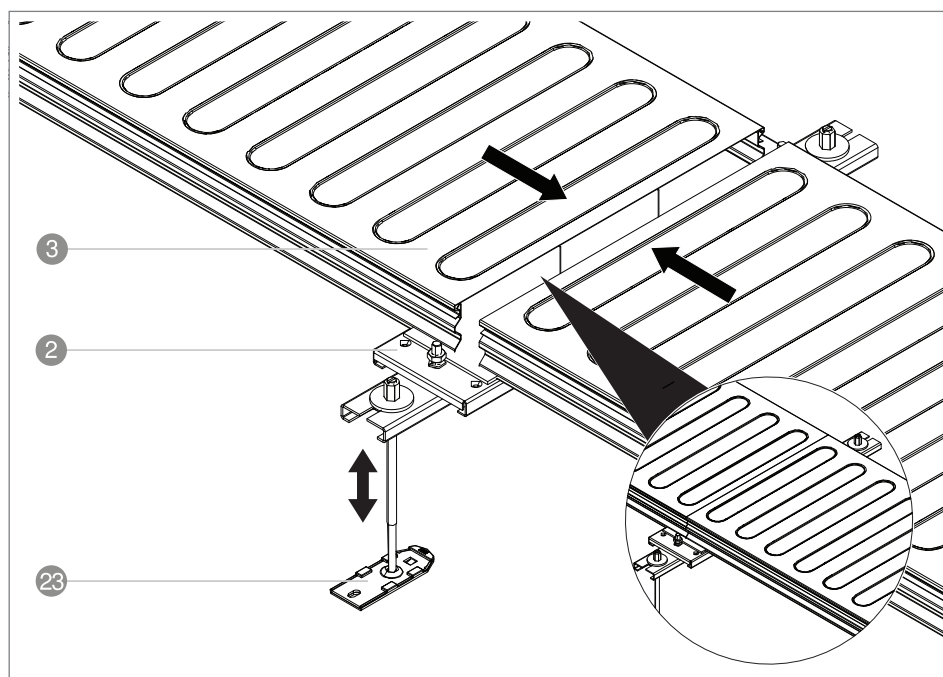

Fig. 18: Adjusting the height of the connection shackles

2. Fasten the connection shackles ② with the base of the height-adjustment unit a on the blinding layer with an OBO anchor and setting iron.
3. Adjust the connection shackles ② to the height of the base plate.

Note!

There may be no gap between the two electrical installation ducts!

4. Push the two electrical installation ducts into the connection shackle until they abut directly.

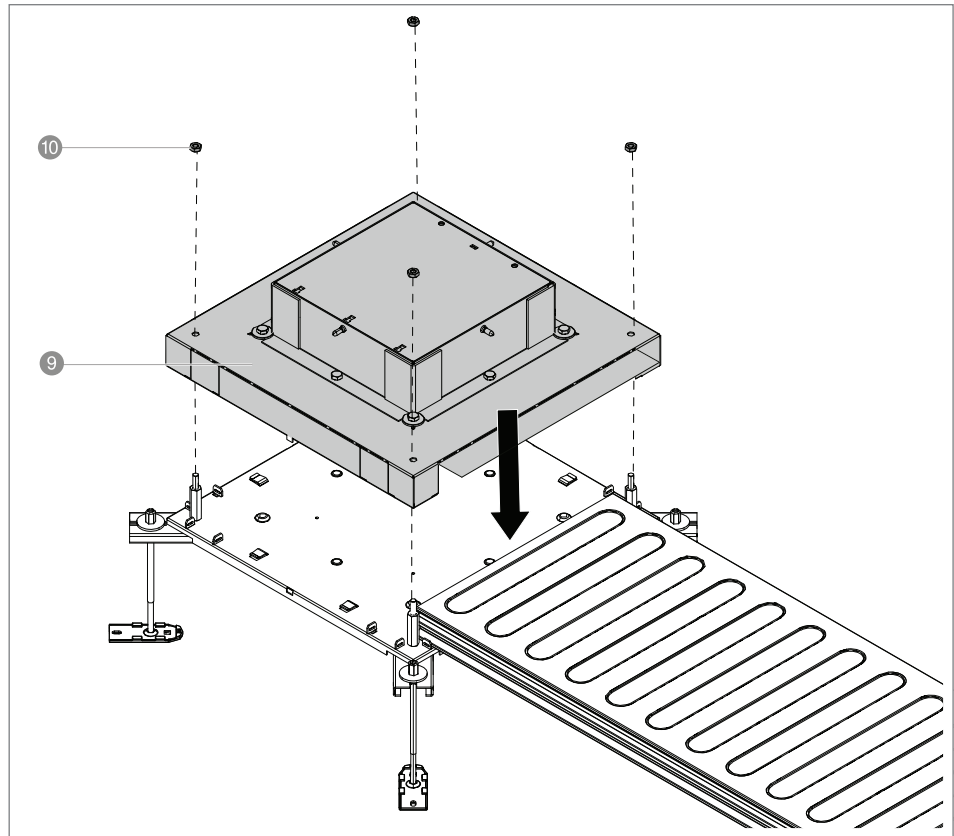

Fig. 19: Positioning the socket body

5. Position the socket body 9 again.
6. Tighten the fastening nuts of the socket body 10.

7.2.2.2 Mounting the duct support

Electrical installation ducts with a length of more than 1 m must be additionally supported. One duct support is to be mounted per running metre and its height adjusted. The support is equipped with two Z profiles, using which the electrical installation ducts are fastened during mounting.

Note! *Z profiles only used for duct support!*

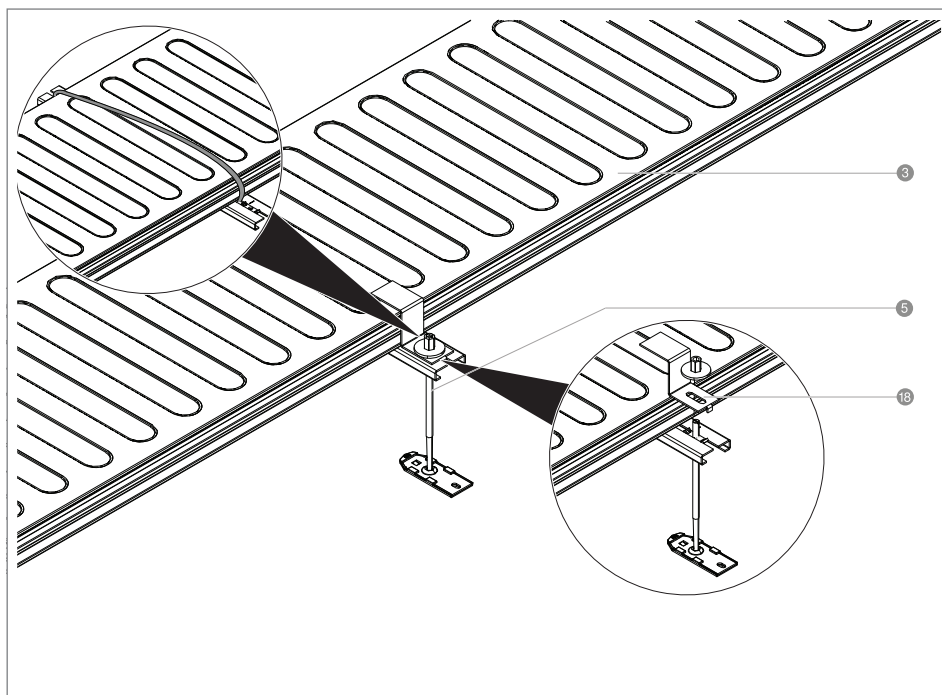

Fig. 20: Mounting the duct support

1. Place the support under the electrical installation duct ③ and suspend it under the electrical installation duct ③ with suitable aids (e.g. wire loop, tape).
2. Insert the height-adjustment units ⑤ in the slots of the support.
3. Screw the height-adjustment units ⑤ to the support. In so doing, the Z profile u of the support must fasten the beading of the electrical installation duct ③.

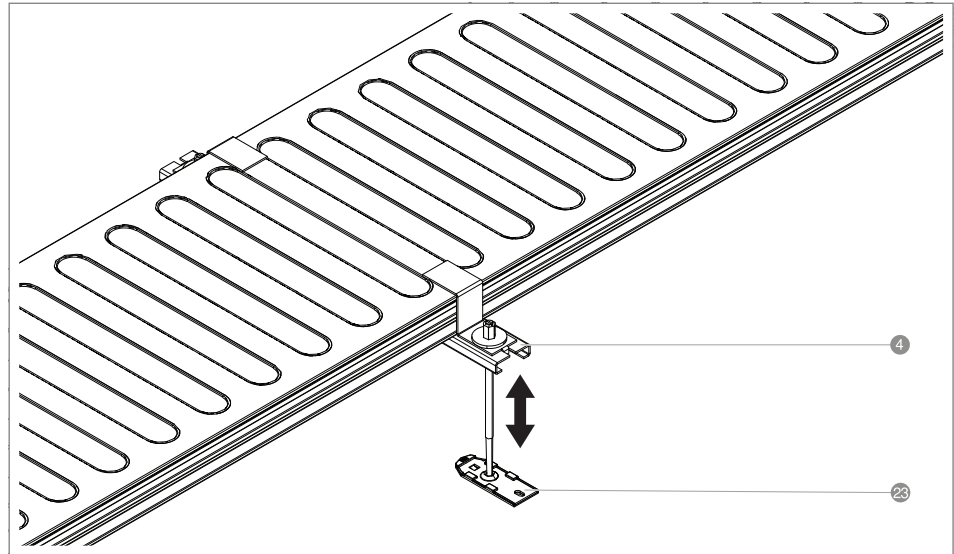

Fig. 21: Adjusting the height of the duct support

4. Fasten the height-adjustment units to the base of the height-adjustment unit 23 on the blinding layer using an OBO anchor with setting iron.
5. Adjust the duct support 4 to the height of the base plate.

7.3 Mount the vertical bend

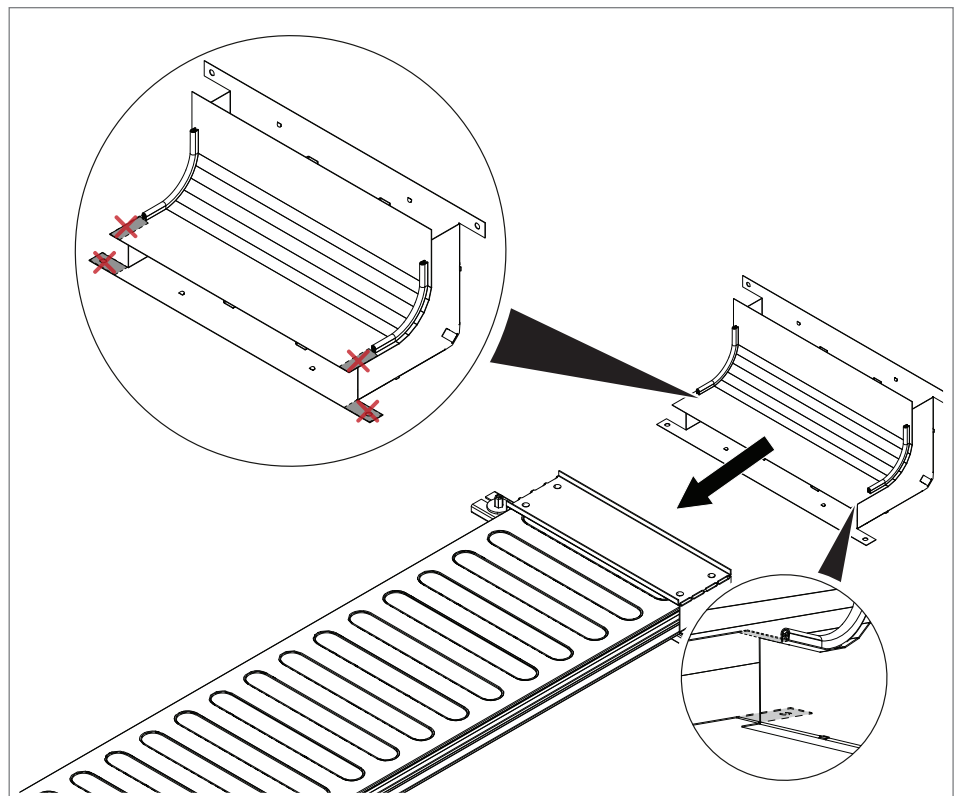

Fig. 22: Mounting the vertical bend

Note! *The vertical bend remains closed and does not need to be dismantled*

for mounting.

1. Remove the straps on the base of the vertical bend ⑥.

Note!

In the following action step, ensure that only the cover is cut and not the side wall.

2. Cut the cover of the vertical bend ⑥ to size.
3. Push the vertical bend 6 into the connection shackle ②.

7.4 Final work before screed laying

If an additional compensation layer is applied after the concrete ceiling, then the inner lined body must be pulled out to the height of the compensation layer (max. 65 mm).

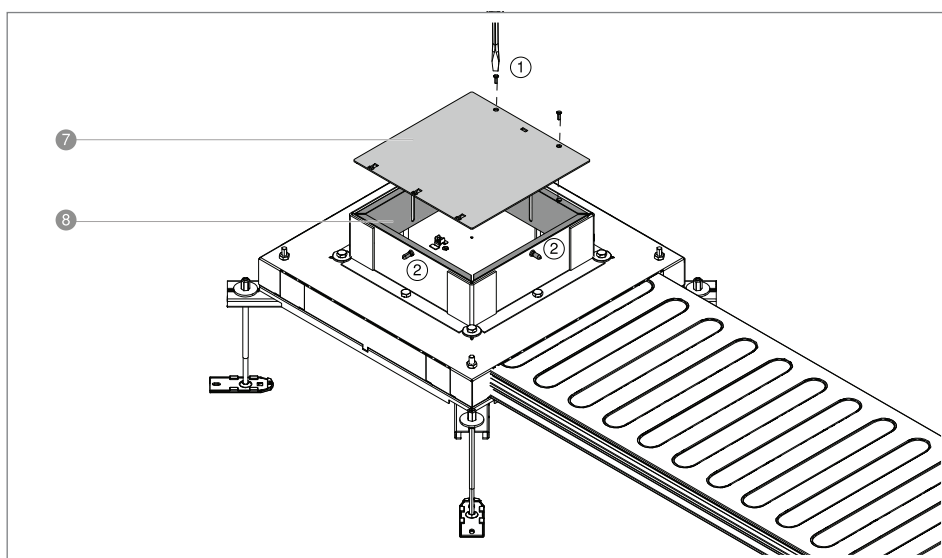

Fig. 23: Removing protective mounting cover

1. Unscrew the mounting protection cover ⑦.
2. Loosen the screws of the inner lined body ⑧ from the upper socket body ⑨.

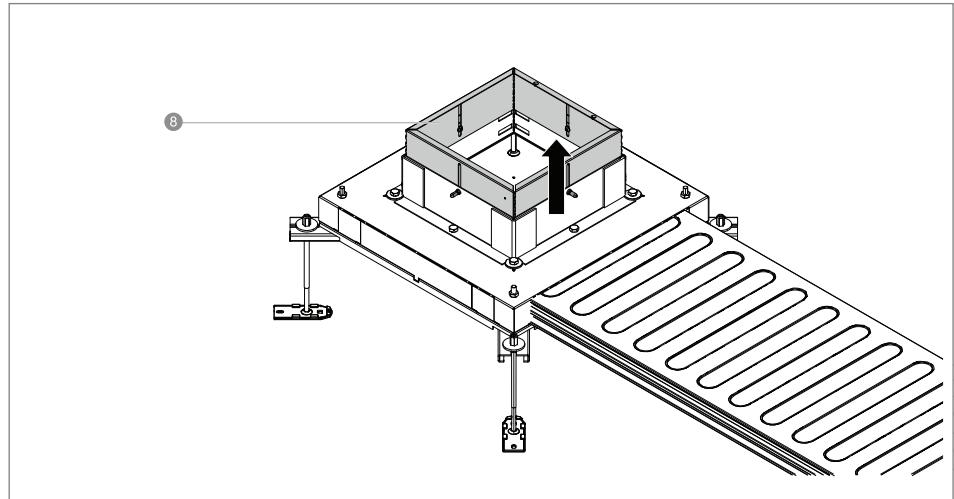

Fig. 24: Pulling out the inner lined body

3. Pull out the inner lined body ⑧ to the height of the future compensation layer, observing the 2 mm height of the mounting protection cover.
4. Retighten the screws of the inner lined body ⑧. Reinsert the mounting protection cover and screw it on.

7.5 Final work after screed laying

After completion of the concrete and screed work, the in-concrete socket can be opened to routing the installation cables and to accept the different service outlets. The mounting protection cover and the inner lined body can be disposed of.

1. Unscrew the mounting protection cover, remove it and dispose of it.
2. Unscrew the inner lined body, pull it out and dispose of it.

8 Creating the earthing connection

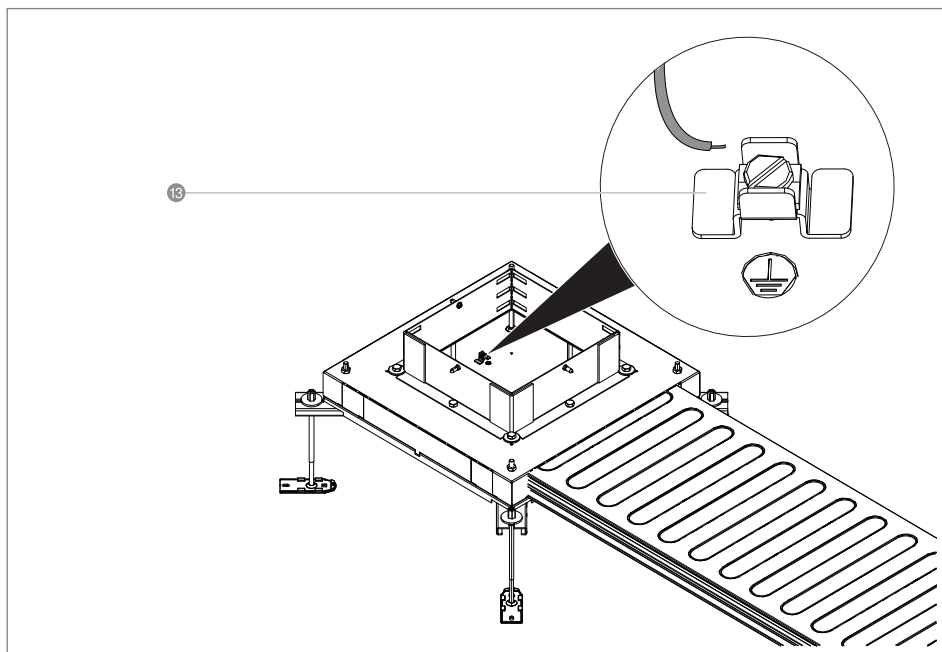

Fig. 25: Creating the earthing connection

1. Loosen the screw of the protective conductor connection bracket 13.
2. Insert the earthing cable.
3. Tighten the screw of the protective conductor connection bracket 13.

9 Applying the floor covering

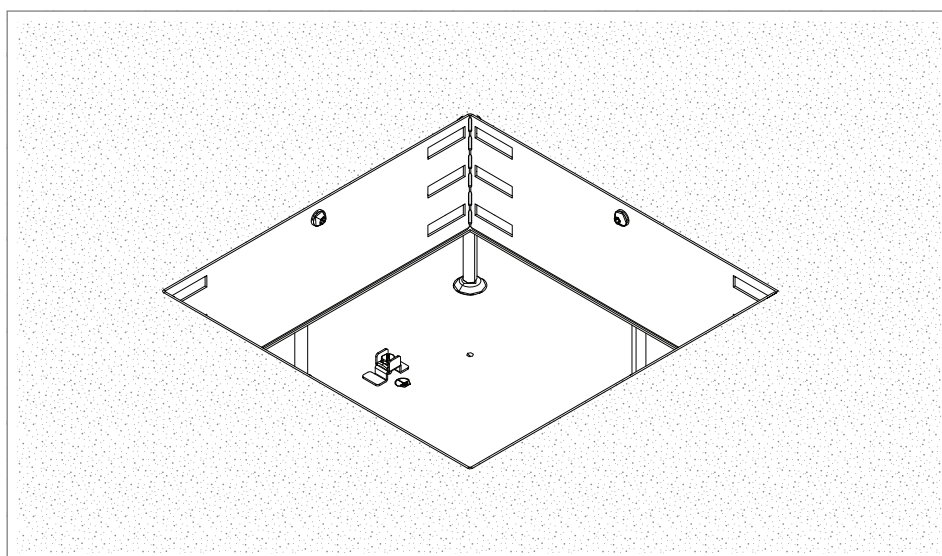

Fig. 26: Applying the floor covering

1. Apply the floor covering up to the mounting lid cut-out.

10 Mounting the cassette/service outlet

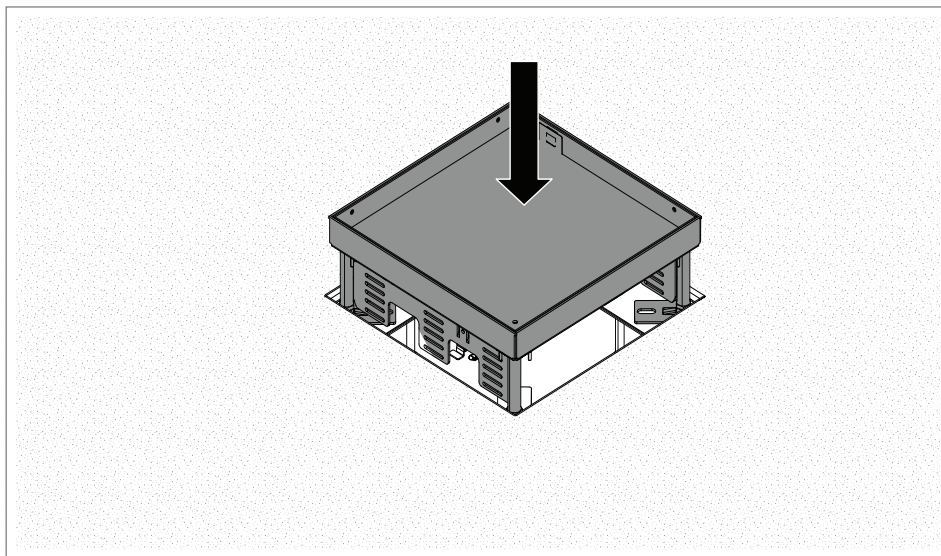

Fig. 27: Mounting the cassette

1. Remove the inner lined body.
2. Mount the cassette/service outlet in the in-concrete socket.

11 Performing the electrical installation

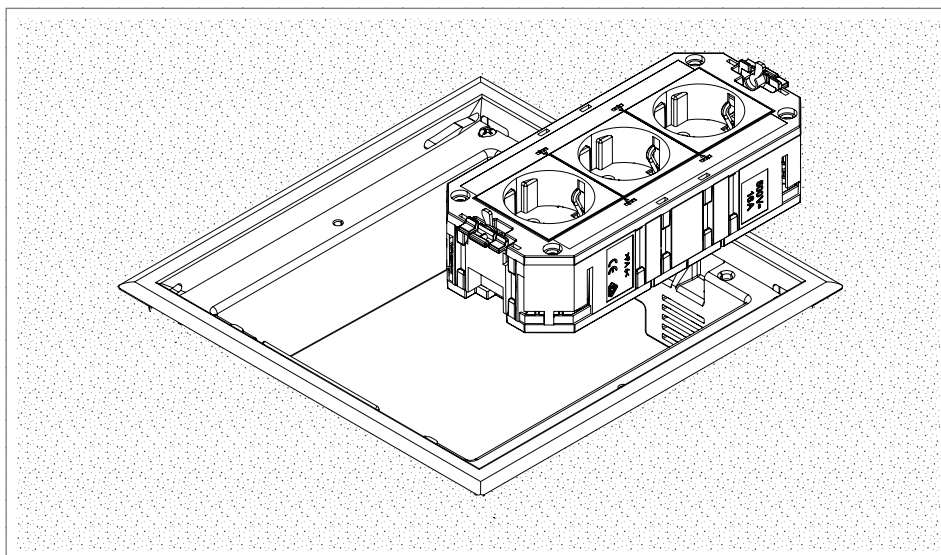

Fig. 28: Performing the electrical installation

Note!

The electrical installation is shown using the example of a universal support.

1. Carry out the electrical installation (in accordance with DIN VDE 100) in the service outlet/cassette.

12 Disposing of the in-concrete duct system

1. Residual metal: As scrap metal
2. Packaging: As household waste

Comply with the local waste disposal regulations.

13 Calculating the length/height ratios

13.1 Calculating the length of the electrical installation duct

After mounting, the electrical installation ducts reach approx. 20 mm into the in-concrete socket on each side.

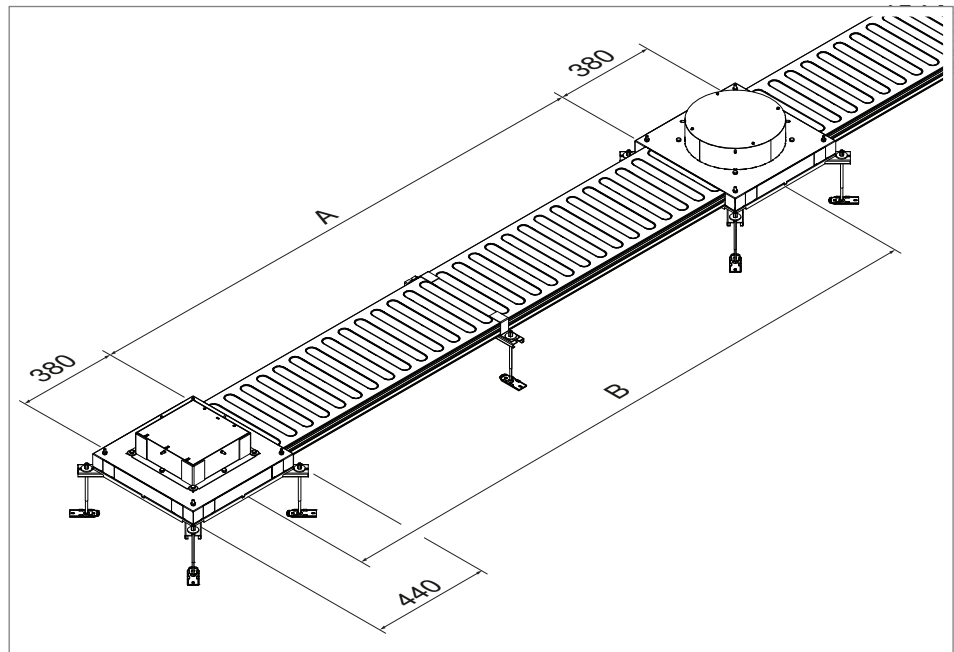

Fig. 29: Length of the electrical installation duct

A Length of the electrical installation duct

B Distance between two in-concrete sockets (centre)

Length of the electrical installation ducts between two in-concrete sockets:

$$A = B - 380 \text{ [mm]}$$

Total length of one strand of electrical installation ducts:

$$(\text{Length of duct}) A - ((\text{number of in-concrete sockets}) n \times 380 \text{ mm})$$

14 Technical data

14.1 In-concrete socket

Item no.	Type	Length	Width	Height	Material
7399850	IBD 35038 9	440 mm	440 mm	135 mm	Steel
7399856	IBD 35038 R9	440 mm	440 mm	135 mm	Steel
7399852	IBD 35048 9	440 mm	440 mm	145 mm	Steel
7399858	IBD 35048 R9	440 mm	440 mm	145 mm	Steel

Tab. 2: Technical data: In-concrete socket

14.2 Underfloor duct

Item no.	Type	Length	Width	Height	Material	Number of compartments
7400267	S2 25038-2	2000 mm	250 mm	38 mm	Steel	Two-compartment
7400269	S2 25048-2	2000 mm	250 mm	48 mm	Steel	Two-compartment
7400279	S3 25038-2	2000 mm	250 mm	38 mm	Steel	3-compartment
7400281	S3 25048-2	2000 mm	250 mm	48 mm	Steel	3-compartment
7400289	S3 35038-2	2000 mm	350 mm	38 mm	Steel	3-compartment
7400291	S3 35048-2	2000 mm	350 mm	48 mm	Steel	3-compartment

Tab. 3: Technical data – underfloor duct

14.3 Vertical bend

Item no.	Type	Width	Height	Material	Number of compartments
7400637	KV2 25038-2	250 mm	38 mm	Steel	Two-compartment
7400641	KV2 25048-2	250 mm	48 mm	Steel	Two-compartment
7400650	KV3 25038-2	250 mm	38 mm	Steel	3-compartment
7400653	KV3 25048-2	250 mm	48 mm	Steel	3-compartment
7400662	KV3 35038-2	350 mm	38 mm	Steel	3-compartment
7400665	KV3 35048-2	350 mm	48 mm	Steel	3-compartment

Tab. 4: Technical data – vertical bend

14.4 Connection shackle

Item no.	Type	Duct width	Duct height	Material
7399890	IBVE 25038	250 mm	38 mm	Steel, strip galvanised
7399896	IBVE 35038	350 mm	38 mm	Steel, strip galvanised

Technical data

Item no.	Type	Duct width	Duct height	Material
7399892	IBVE 25048	250 mm	48 mm	Steel, strip galvanised
7399898	IBVE 35048	350 mm	48 mm	Steel, strip galvanised

Tab. 5: Technical data – connection shackle

14.5 Support element

Item no.	Type	Duct width	Height	Material
7399914	IBST 25038	250 mm	38 mm	Steel, strip galvanised
7399915	IBST 25048	250 mm	48 mm	Steel, strip galvanised
7399917	IBST 35038	350 mm	38 mm	Steel, strip galvanised
7399918	IBST 35048	350 mm	48 mm	Steel, strip galvanised

Tab. 6: Technical data – support element

14.6 Height adjustment unit

Item no.	Type	Height-adjustment range	Material
7399920	IBNEV 110	35–105 mm	Steel, strip galvanised
7399923	IBNEV 150	75–145 mm	Steel, strip galvanised
7399926	IBNEV 190	115–185 mm	Steel, strip galvanised
7399929	IBNEV 230	155–225 mm	Steel, strip galvanised

Tab. 7: Technical data – height-adjustment unit

OBO Bettermann Holding GmbH & Co. KG

P.O. Box 1120
58694 Menden
GERMANY

Customer Service Germany

Tel.: +49 (0)2373 89-1300

toi@obo.de

www.obo-bettermann.com

Date 04/2024

230085.03

Building Connections

